

# WATER WATCH INSTALLATION INSTRUCTIONS (BATTERY)

<http://www.urinalflushcontrol.co.uk>

## Description of Operation

The valve controls the water supply to the cistern and is electrically operated by the Water Watch controller. The controller detects individuals using the urinals. A flush cycle starts with a detection followed by a delay (20min default) set by the installer and then followed by a flush. At the end of a cycle the controller waits for a further detection before the next flush cycle commences. If a period of 24 hours (or 12 hrs) elapses without detection a flush will occur.

- 2** **CUT PIPE AND FLUSH OUT WITH WATER**  
FIT VALVE HORIZONTALLY (VERTICALLY IN DIRECTION OF ARROW)  
LEAVING THE PETCOCK IN PLACE

*NOTE: VALVE ACTUATOR CAN BE ROTATED BY REMOVING  
THE PLASTIC SPLIT WASHER*

- 1** **ISOLATE SUPPLY**

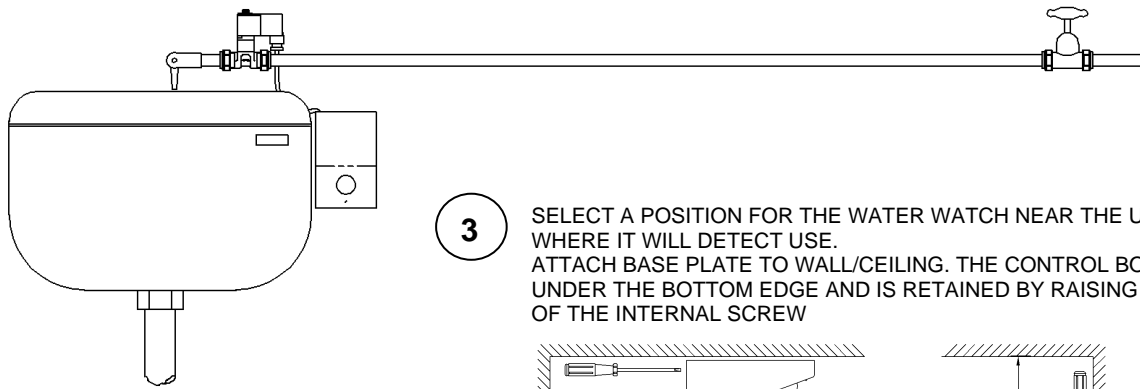

- 3** **SELECT A POSITION FOR THE WATER WATCH NEAR THE URINALS**  
WHERE IT WILL DETECT USE.  
ATTACH BASE PLATE TO WALL/CEILING. THE CONTROL BOX HOOKS  
UNDER THE BOTTOM EDGE AND IS RETAINED BY RAISING THE HEAD  
OF THE INTERNAL SCREW

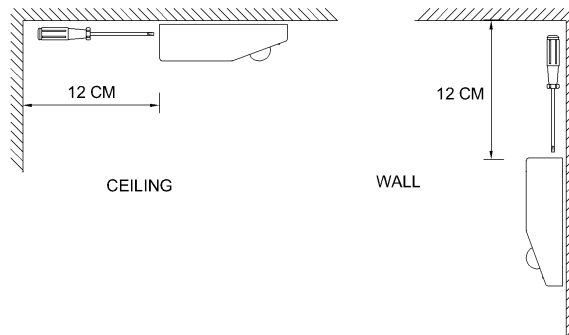

- 4** **CABLE BETWEEN VALVE CONNECTOR AND WATER WATCH CONTROLLER.** LEAVE A SMALL LOOP INSIDE THE  
CONTROLLER SO THE LID CAN BE DETACHED FROM THE MOUNTING PLATE.

*NOTE: ALTERNATIVELY FEED CABLE THROUGH TOP CABLE BLAND AND USE TRUNKING*

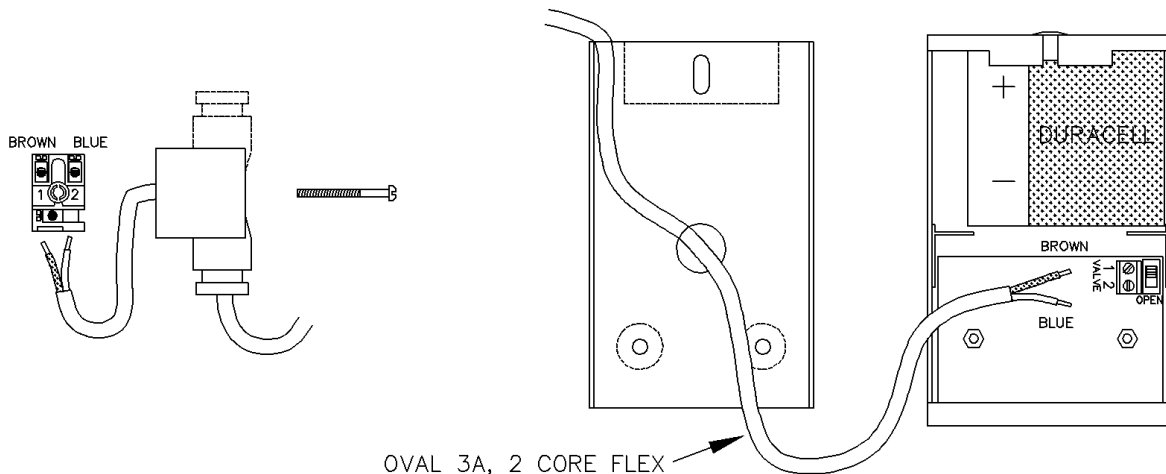

5

**FOLLOW THESE THREE STEPS TO SETUP THE WATER WATCH**

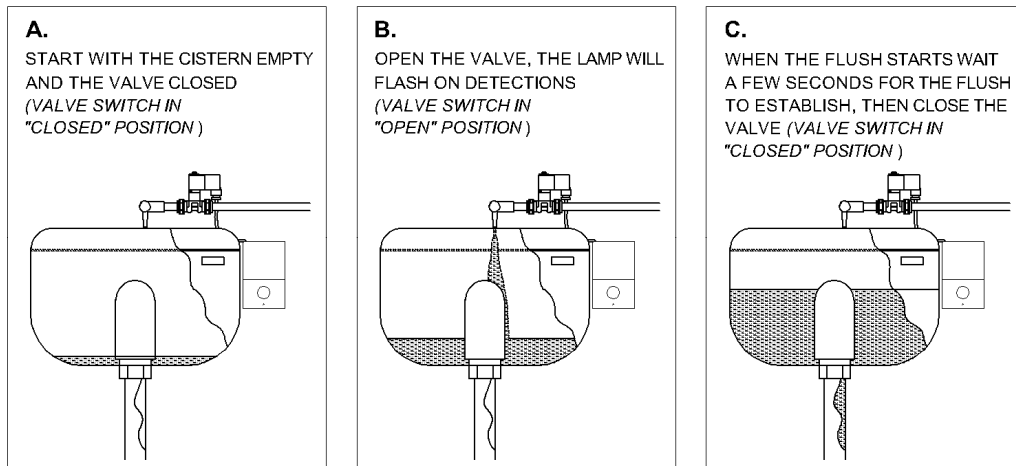

THE TIME TAKEN FOR THE CISTERN TO FILL DURING SETUP IS STORED AND USED ON ALL SUBSEQUENT AUTOMATIC FLUSHES.

THE WATER WATCH IS NOW FULLY OPERATIONAL! – CLOSE THE LID. IF THE LAMP IS FLASHING CHECK THAT THE SWITCH IS IN THE CORRECT "CLOSED" POSITION. THE SWITCH MUST NEVER BE LEFT IN THE "OPEN" POSITION.

THE LAMP WILL NOW ONLY OPERATE WHEN THE BATTERY NEEDS CHANGING.

**CHANGING THE FLUSH SETTINGS**

